

# RESIDENTIAL SEPTIC TANK ACCESS OPENING RISERS

MODEL 2428  
24" I.D., 2" WALL

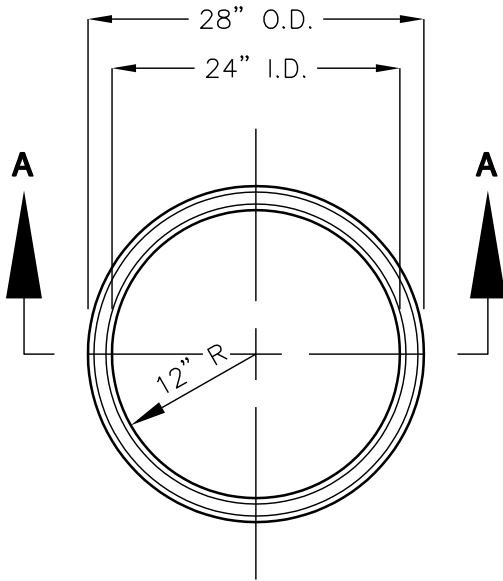

TOP VIEW  
MODEL 2428 RISER

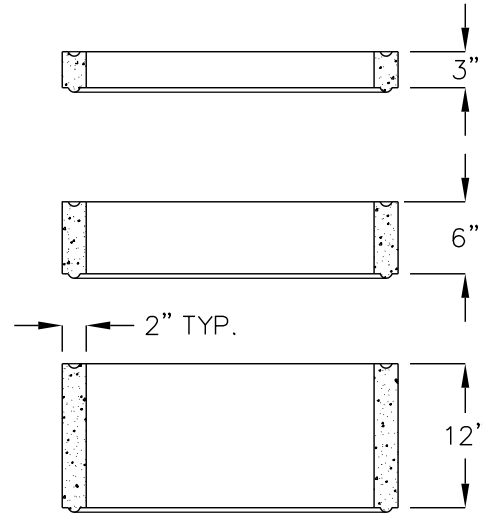

SECTION A-A

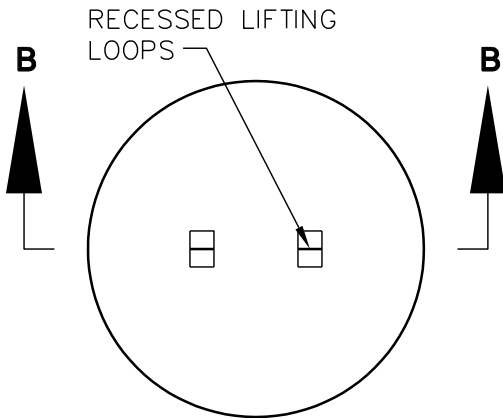

TOP VIEW  
SOLID CONCRETE COVER



SECTION B-B

DESCRIPTION	MODEL NO.	PRODUCT WEIGHT	*RISERS PER BUNDLE
3" RISER	2428 GR-03	34 LBS.	19
6" RISER	2428 GR-06	69 LBS.	10
12" RISER	2428 GR-12	137 LBS.	5
CONC. COVER	2428-S-COVER	130 LBS.	N/A

\*RISER BUNDLES ARE BANDED TOGETHER AND SHIPPED HORIZONTALLY.

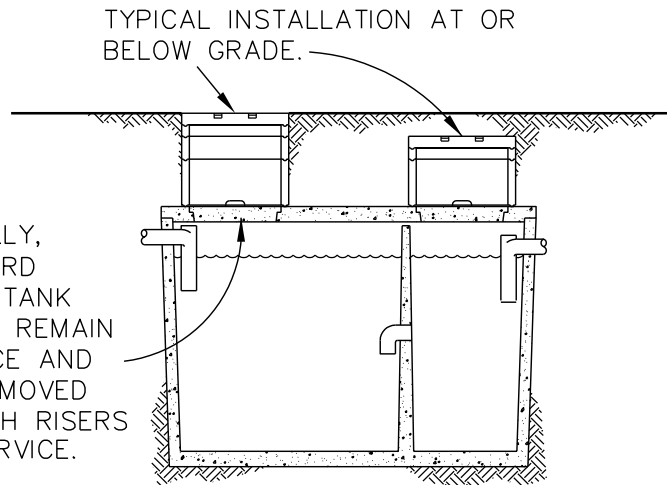

SEPTIC TANK SECTION

**\*\* DESIGN LOAD:**  
RISERS AND COVER ARE DESIGNED FOR 2,500 LB. WHEEL LOAD MAXIMUM.  
FOR COMPLETE DESIGN AND PRODUCT INFORMATION, CONTACT JENSEN PRECAST.

**\*\* CAUTION:** DESIGN LOAD OF TANK MAY BE LESS THAN 2,500 LBS. WHEEL LOAD.