

# HJ1000-HJ1500 GALLON SAND-OIL INTERCEPTORS-HAWAII

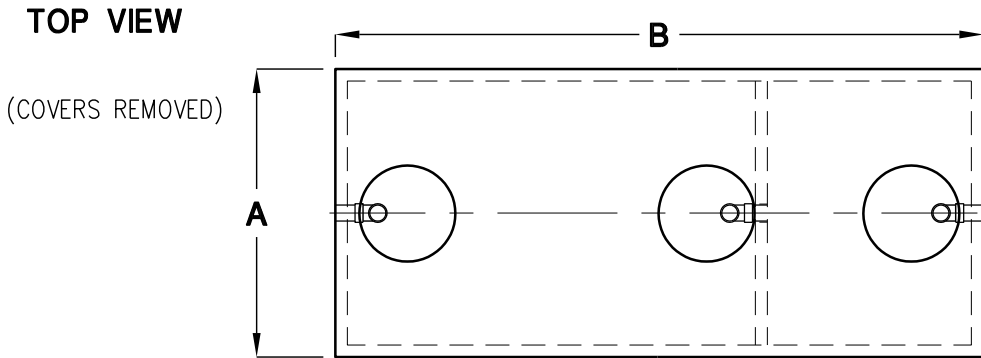
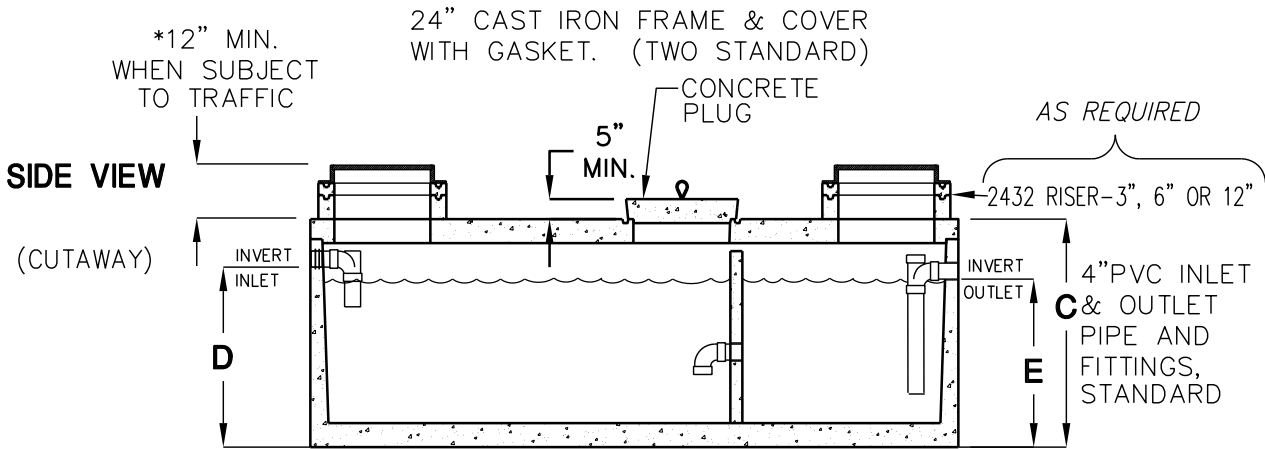

MODEL NUMBER	LIQUID CAPACITY GALLONS	WIDTH 'A'	OVERALL LENGTH 'B'	TANK HEIGHT 'C'	INLET 'D'	OUTLET 'E'	MINIMUM EXCAVATION WIDTH	MINIMUM EXCAVATION LENGTH	*DEPTH OF BURY	TANK WEIGHT LBS.
HJ1000SO	1000	6'-0"	9'-4"	4'-9"	3'-9"	3'-6"	7'-0"	10'-4"	6' MAX.	14,100
HJ1250SO	1250	6'-0"	11'-6"	4'-9"	3'-9"	3'-6"	7'-0"	12'-6"	6' MAX.	16,650
HJ1500SO	1500	6'-0"	13'-6"	4'-9"	3'-9"	3'-6"	7'-0"	14'-6"	6' MAX.	19,300

- TANK DESIGNED FOR H-20 TRAFFIC WHEEL LOAD WITH 1' TO 6' MAX. EARTH COVER AND WATER TABLE AT ONE FOOT BELOW GRADE.
- SUITABLE NATIVE SOIL OR GRANULAR SUB-BASE SHALL BE COMPACTED AND LEVELED TO HANDLE ANTICIPATED LOADS. SEE INSTALLATION PROCEDURES SHEET FOR ADDITIONAL INFO.
- EXTERIOR AND INTERIOR CONCRETE SURFACES TO BE COATED WITH AN APPROVED BITUMINOUS MATERIAL.
- FOR COMPLETE DESIGN AND PRODUCT INFORMATION CONTACT JENSEN PRECAST.

THE DESIGN AND DETAIL OF THIS DRAWING ARE THE PROPERTY OF JENSEN PRECAST AND NOT TO BE USED EXCEPT IN CONNECTION WITH ITS OWN WORK. DESIGN AND INVENTION RIGHTS ARE RESERVED.