



UNDERGROUND WASTE-WATER PRECAST CONCRETE TANK INSTALLATION PROCEDURE

Rev 01/20/10

Jensen Precast has provided this document to assist and direct specifiers, municipalities and our customers involved in the specifying, purchasing and installing of underground precast concrete wastewater tanks and structures. It is paramount that these instructions and directives are followed closely and not circumvented. For a copy or additional information please visit www.jensenprecast.com. Contact Jensen Precast for additional information on any portion of this Installation Policy and Procedure.

INDEX

1. GENERAL INSTALLATION POLICY INFORMATION
2. EXCAVATION AND SITE PREPARATION
3. SETTING AND INSTALLATION
4. VENTILATION
5. TANK SEALING
6. BACKFILLING
7. WATERTIGHT TESTING OVERVIEW
8. PRE-TEST INSPECTION
9. WATER TESTING TANKS UP TO 1500 GALLONS
10. WATER TESTING TANKS 2000 GALLONS AND GREATER
11. VACCUM TESTING
12. PRECAUTIONARY NOTE
13. ACCEPTANCE

1. GENERAL INSTALLATION POLICY INFORMATION

The policy contained herein describes specific policy information and purchaser requirements for underground wastewater precast concrete tanks and structures (hereon referred as TANK, including grease interceptors, sand-oil interceptors, sand traps, stormwater interceptors, septic tanks, clarifiers and holding tanks. Other Jensen Precast company policies, including shipping, terms and conditions, ordering instructions, and others also apply. Contact Jensen Precast for complete information.

In general, Jensen Precast provides delivery and setting of the TANK and sealing of the TANK in accordance with the provisions of this policy. In a situation where our truck cranes cannot set the TANK for whatever reason, we will provide a representative to supervise in the proper setting of the TANK and then seal the primary components as specified herein.

Jensen Precast accepts responsibility for proper setting, assembly, and sealing of the TANK when installed or supervised by Jensen Precast or an authorized representative. A TANK handled, moved, or installed without Jensen Precast supervision, could nullify Jensen Precast's responsibility of warranty.

NOTE: Failure to follow proper TANK installation and or sealing procedures may result in structural damage to the system or compromise its functional design along with nullifying product warranties.

2. EXCAVATION AND SITE PREPARATION

The TANK must be set on a properly prepared base to ensure against movement of either the TANK or the inlet and outlet lines. The excavation shall be the proper width and length to accept the model selected and shall have enough extra width and length to allow for safe installation and sealing of the components. Suitable native soil or sub-base shall be prepared to handle anticipated loads. The excavation shall be bedded with suitable granular material and shall be compacted to 90% of it's maximum dry density in accordance with ASTM D 1557 or to the requirements of the project geotechnical engineer. The bottom of the excavation shall be graded level.

The area around the tank must be cleared to a minimum of 2' around the tank and 3' around any joint to be sealed. The excavation's slope, benching or shoring shall comply with the requirements of OSHA 29 CFR 1926 Subpart P. Jensen Precast will not violate this OSHA standard in the course of setting and sealing the TANK.

On battery TANK systems (multiple-tanks joined together) with capacities in excess of 5,000 gallons, redwood grade boards shall be used to ensure a level and stable tank joint. A minimum of two 2" x 6" grade boards, laid flat, running the full length of the entire TANK assembly directly under the outside walls shall be used. The top of the compacted fill material shall match the top of redwood grade boards prior to setting the TANK. A stringline or other suitable means for aligning tanks shall be provided and in place prior to installation.

The owner, customer, contractor, or others shall be responsible for the following:

1. Two workers or laborers to direct and assist the setting of, and location of the TANK.
2. Providing a properly prepared, sized, compacted base and graded excavation.
3. Supplying and installing redwood grade boards under battery TANK.
4. Providing job site safety, excavating safety, shoring as required, water and or flotation control.
5. Completing the entire installation and all other site work not specified herein.

3. SETTING AND INSTALLATION

Jensen Precast requires assistance from the customer or contractor in setting, sealing, and placing the TANK (**a minimum of two workers is required**). Access and setting location for our boom truck or other equipment must be acceptable to our driver or representative. Tanks 2000 gallons and larger require extreme caution due to the weight of the product. There may be situations where an outside crane may be needed to set the product. Contact Jensen Precast for details.

Since site conditions, products, and delivery equipment vary tremendously, the logistics must be carefully considered to determine the best possible approach for delivery and setting, including but not limited to:

1. The capacity of the crane, whether it's a Jensen Precast truck crane or contractor's crane to be used.
2. The maximum product weight relative to the setting distance from the center of the crane to the center of the excavation which cannot exceed our truck crane's rated capacity and setback distance from the excavation.
3. The type of terrain, site slope, and ground conditions for outrigger footing.
4. The access route for boom truck or other equipment.
5. The overhead restrictions (power lines, trees etc) and other physical constraints.

ANY of the above could prevent Jensen Precast from setting the TANK.

NOTE: If for any reason Jensen Precast cannot set the TANK, Jensen Precast will not be responsible or charged for setting by any other means.

Check that the tank is level while connected to the crane.

The owner, customer, contractor, or others shall be responsible for the following:

1. Finished grading, leveling and positioning of TANK, and access openings.
2. Grouting, sealing, setting and adjusting of grade rings, risers, frames, covers, and all other hardware and appurtenances.
3. Supplying and installing inlet and outlet pipes.
4. Sealing above the top of the TANK.
5. Any and all permits, licenses, tests, or approvals from any administrative authority that are required for installation of the TANK.

4. VENTILATION

The TANK is equipped with inlet & outlet tee's which allow gases to escape the TANK atmosphere into the building plumbing / ventilation system as prescribed by the *Uniform Plumbing Code* (UPC) unless local regulations supercede. Failure to provide proper ventilation for the TANK could result in an odor problem. Please consult the *Uniform Plumbing Code* and/or local regulations for additional information. If additional venting requirements are required, contact Jensen Precast.

5. TANK SEALING (BATTERY TANKS AND TANKS WITH HORIZONTAL SEAMS)

For installation of sectional TANKs requiring job site joint sealing, Jensen Precast will seal the TANK only. The owner, customer, or contractor shall be responsible for sealing or grouting of grade rings, risers, covers, inlets and outlets if required. The TANK must be dry in order for the sealant to bond properly to the concrete. The sealant must completely cure according to the time table below before conduction a water-tight testing.

Type of Water Test	Ambient Temperature	Cure Time (hours)
To Operation Level	Greater Than 70° F	24
	Less Than 70° F	48
To Top of Tank	All	72

Failure to follow these guidelines or not allowing for a full cure of the joint sealant could cause the TANK to fail water testing and possibly void Jensen Precast responsibility and product warranty.

6. BACKFILLING

Failure to comply with proper backfill procedures could result in structural damage or leakage from pipe connections, or leakage from the TANK, due to settling, point loading, impacting, etc. Backfill shall be suitable clean material and shall be laid in lifts limited to 24" and adequately compacted from bottom to top to prevent movement or settling under the pipe or fittings. **Only mechanical backfilling methods can be utilized; water-jetting (liquefaction of backfill dirt) is not acceptable and could damage the TANK.**

CAUTION: High slump or flowable backfill like cement slurries must not be laid in lifts greater than 24” and must be allowed to set up before the next lift is laid. It is recommended that before using flowable backfills, contact Jensen Precast to discuss procedures for your application.

7. WATERTIGHT TESTING OVERVIEW

When watertight testing is required during inspection, testing must be completed and approved after installation, but before the tank is put into service. Testing for watertightness shall be performed using either hydrostatic water test or vacuum test per ASTM C1227-09 section 9 or ASTM C1613 section 9. Standard water test are conducted up to the outlet of the tank per ASTM. Although ASTM does not address infiltration tests for tanks equipped with top slabs, if required they are conducted up to the top of the top of slab following ASTM procedures.

Warning: Water tests conducted above the lid of the tank may have structural implications and could exceed the structural design of the tank. Contact Jensen Precast for complete details.

TANK with capacities of 2000 gallons or greater have specific backfill requirements before water testing. See section 10.

The owner, customer, contractor, or others shall be solely responsible for the following:

1. Conducting and approval of the test.
2. Providing water and means to pump or evacuate water for testing or any subsequent retesting.
3. Providing the vacuum pump, seals for access opening and pipe plugs.
4. Sealing or testing grade rings, risers, covers, other openings, etc.
5. Any required sealing and testing of inlet and outlet pipelines.

8. PRE-TEST INSPECTION

Before any applicable tests are performed and before the TANK is placed into service, a visual inspection is to be performed to insure that the TANK is free of trash and debris that could prevent the TANK from functioning properly. All foreign objects such as rocks, trash, tools, or construction materials left inside the TANK from the installation process should be removed and properly disposed. Check that the tank is level.

Check that the inlet and outlet pipe are properly connected and sealed to the tank. Check the tank inlet, baffle and outlet have the appropriate pipe fitting attached and have no obstructions.

9. WATER TESTING TANKS UP TO 1500 GALLONS

The TANK shall be filled to the operational liquid level (outlet invert) with water and allowed to stand to achieve complete concrete absorption, then refilled to the same level. Once refilled, there shall be no measurable liquid loss in the following hour. (Ref. ASTM C-1227-07 9.2.2)

10. WATER TESTING TANKS 2000 GALLONS AND GREATER

All TANKS of 2000 gallon capacity or greater and all battery TANKS must be backfilled to the outlet pipe when water testing. **Warning: Water testing tanks with a liquid capacity of 2000 gallons or greater without backfilling could damage the tank.** The TANK shall be filled to the operational liquid level with water and allowed to stand to achieve complete concrete absorption, then refilled to the same level. Once refilled, there shall be no measurable liquid loss in the following hour. (Ref. ASTM C-1227-07 9.2.2)

If the Administrative Authority requires visual inspection of the exterior walls during the water test, then use the following procedures.

SINGLE TANK UNITS: Backfilling in increments can accomplish an exterior wall inspection when done in 2 foot lifts. To begin introduce, 2 feet of water in the bottom of the TANK. Once inspected, backfill and compact 2 feet of the outside walls, after compaction add an additional 2 feet of water into the tank. Inspect the outside walls as previously done and repeat these procedures until completely inspected and backfilled.

MULTIPLE TANKS IN A BATTERY CONFIGURATION: Backfilling, in increments can accomplish an exterior wall inspection when done in 2 foot lifts. However, prior to the introduction of water to the tanks, all outside walls should be backfilled and compacted to a minimum of 2 feet. Subsequently, 2 feet of water can be introduced to the TANK and the same procedure followed as above.

Bypassing or ignoring any of these requirements (to any degree) could cause damage to the TANK and void the Jensen Precast warranty.

For additional information or clarification please contact Jensen Precast

11. VACCUM TESTING

This test method is intended to be used to demonstrate the condition of the installed system prior to backfill.

WARNING: Testing of the system before backfill is necessary so as to preclude inadvertent structural overloading of the system components during the test. Follow procedures set forth in ASTM 1613 and C1227.

Seal the tank and apply a vaccum of 4" of mercury. Hold the vaccum for 5 minutes. During the initial 5 minutes, the vaccum shall not drop more than ½" of mercury, which allows for equipment pressure equalization loss. If the vaccum drops, it shall be brought back up to 4" of mercury and held for additional 5 minutes with no vaccum loss. If the tank fails the test, it shall be repaired and retested.

12. PRECAUTIONARY NOTE

Underground TANKs, and other similar type enclosures are confined spaces and entry is not recommended as the atmosphere may be hazardous. If entry is necessary, enter only with the proper equipment and follow O.S.H.A. confined space entry procedures.

Jensen Precast recommends that all applicable O.S.H.A. recommendations are read and followed, including the current section on confined spaces and "Permit Required Confined Space".

This warning is presented for precautionary safety advice only. Owners, users, installers, contractors, etc. are responsible for job site safety and O.S.H.A. compliance.

13. ACCEPTANCE

Jensen Precast's responsibility for the TANK installation and sealing shall be considered finished and the tank shall be considered accepted by the owner once *any* of the following occurs:

1. The owner, contractor, customer, or engineer accepts the system.
2. A watertightness test has been completed and satisfactorily passed.
3. The TANK has been placed in service.
4. The safety conditions on the job site are not acceptable to Jensen Precast or its authorized representative.
5. Failure or gross neglect in following the instructions contained herein.

COMMERCIAL TANK EXCAVATION AND SITE PREPARATION

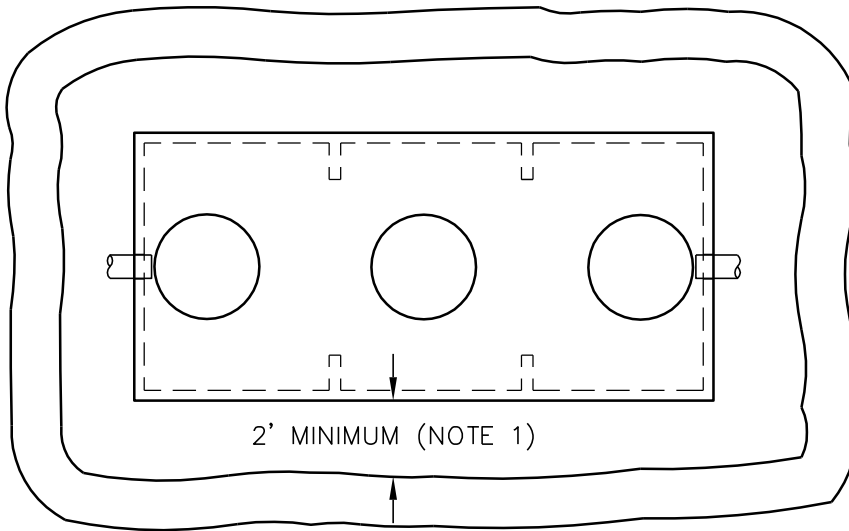

PLAN VIEW
(COVERS & RISERS REMOVED)

EXCAVATION
(NOTES 1 AND 2)

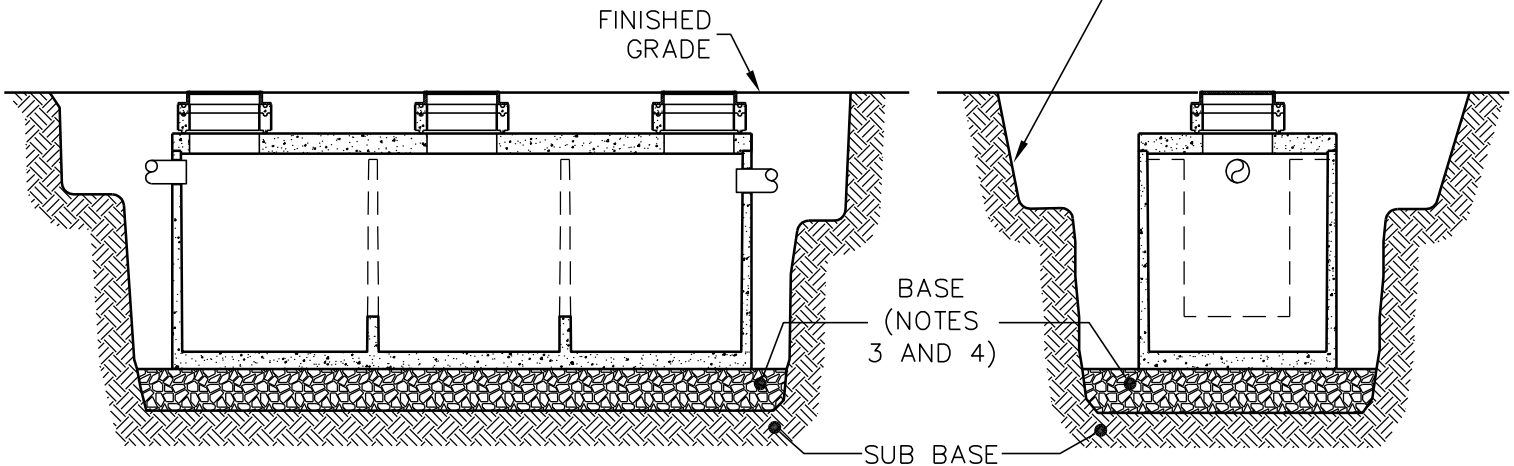

**SIDE ELEVATION
SECTION**

**END ELEVATION
SECTION**

NOTES:

1. AREA MUST BE PREPARED AND CLEARED TO 2 FEET MINIMUM SURROUNDING ENTIRE TANK.
2. THE EXCAVATION'S SLOPE, BENCHING OR SHORING SHALL COMPLY WITH THE REQUIREMENTS OF OSHA 29 CFR 1926 SUBPART P. JENSEN PRECAST WILL NOT VIOLATE THIS OSHA STANDARD IN THE COURSE OF SETTING AND SEALING THE TANK.
3. BASE MUST BE LEVEL AND EVEN IN ALL DIRECTIONS.
4. THE EXCAVATION SHALL BE BEDDED WITH SUITABLE GRANULAR MATERIAL AND SHALL BE COMPACTED TO 90% OF IT'S MAXIMUM DRY DENSITY OR TO THE REQUIREMENTS OF THE PROJECT GEOTECHNICAL ENGINEER.

DRAWING NOT TO SCALE

Jensen Precast reserves the right to make changes to product design and/or dimensions without notice. Please contact Jensen Precast whenever necessary for confirmation or advice on product design.

NOTES:

1. AREA MUST BE PREPARED AND CLEARED TO 2' MINIMUM SURROUNDING ENTIRE TANK.
2. AREA MUST BE PREPARED AND CLEARED TO 3'x3' IN ANY SEAM OR JOINT AREA PRIOR TO DELIVERY.
3. THE EXCAVATION'S SLOPE, BENCHING OR SHORING SHALL COMPLY WITH THE REQUIREMENTS OF OSHA 29 CFR 1926 SUBPART P. JENSEN PRECAST WILL NOT VIOLATE THIS OSHA STANDARD IN THE COURSE OF SETTING AND SEALING THE TANK.
4. PLACE 2" X 6" REDWOOD GRADE BOARDS UNDER TANK LENGTHWISE ALONG SIDES. EXTEND BOARDS BEYOND TANK ENDS.
5. BASE MUST BE LEVEL AND EVEN IN ALL DIRECTIONS.
6. THE EXCAVATION SHALL BE BEDDED WITH SUITABLE GRANULAR MATERIAL AND SHALL BE COMPACTED TO 90% OF IT'S MAXIMUM DRY DENSITY OR TO THE REQUIREMENTS OF THE PROJECT GEOTECHNICAL ENGINEER.
7. STRING LINE OR OTHER SUITABLE MEANS FOR ALIGNING TANKS MUST BE PROVIDED AND IN PLACE PRIOR TO INSTALLATION.

BATTERY TANK

EXCAVATION AND SITE PREPARATION

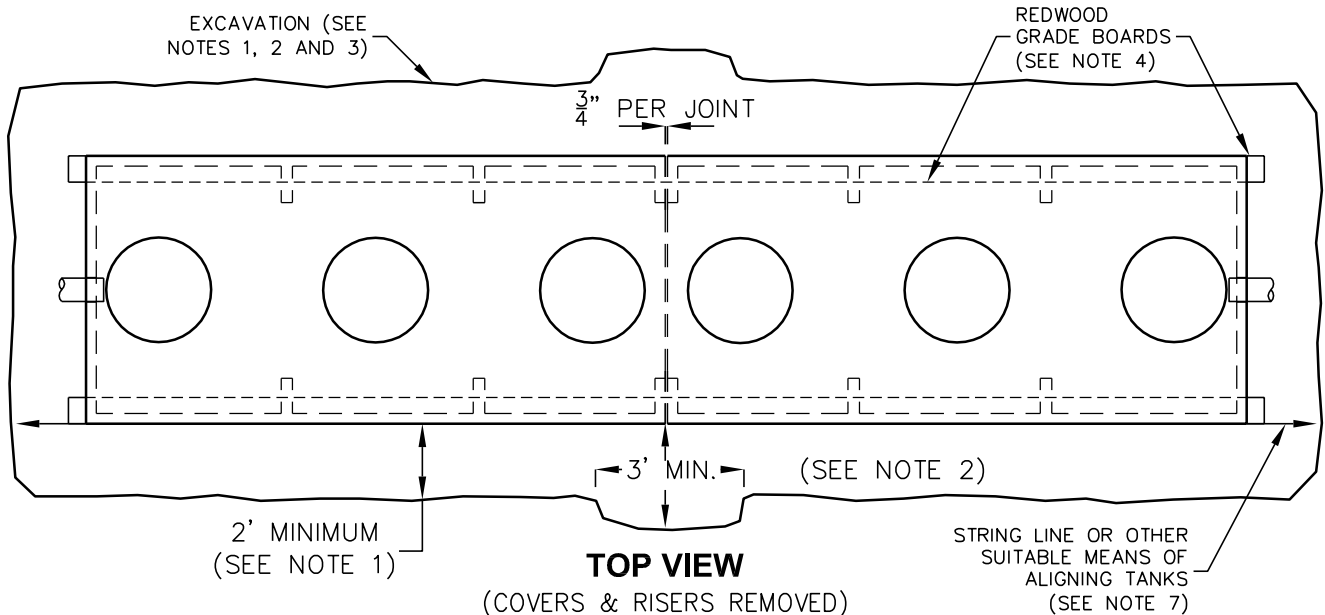
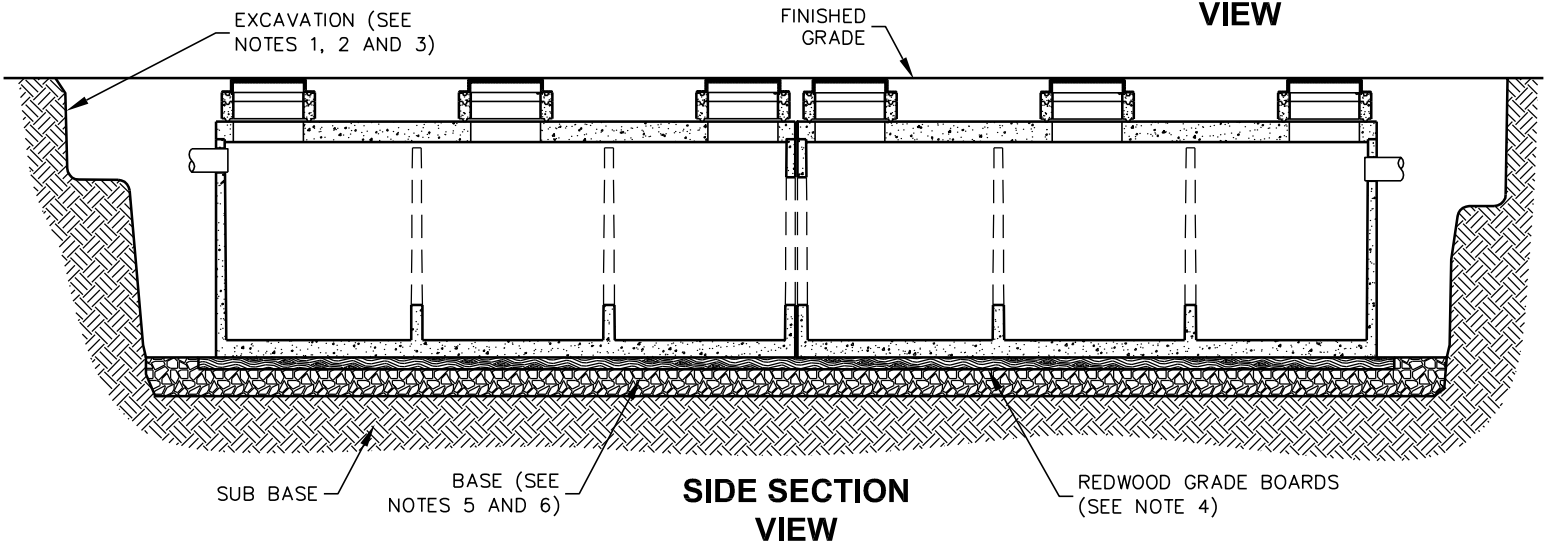
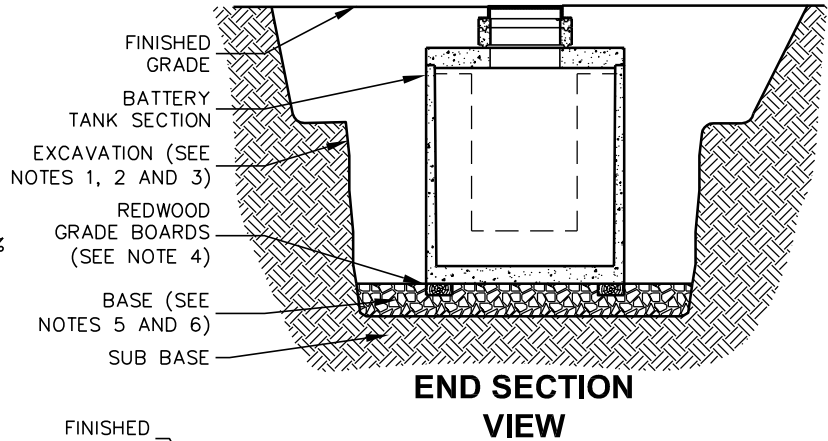

DRAWING NOT TO SCALE

Jensen Precast reserves the right to make changes to product design and/or dimensions without notice. Please contact Jensen Precast whenever necessary for confirmation or advice on product design.

