

# 6'-0" x 6'-0" SCG PARKWAY VAULT W/FLOOR (N399779) x 52" DEEP-4" REGULATOR

- NOTES:**
- HANDHOLE DESIGNED IN ACCORDANCE WITH ASHTO H-20-44 TRAFFIC BRIDGE LOADING USING 5,500 PSI [37.92MPa] COMPRESSIVE STRENGTH CONCRETE AND 60,000 PSI [413.2MPa] YIELD STRENGTH ASTM A-706 STEEL REINFORCEMENT PER CALCS. #
  - COVER DESIGNED FOR PARKWAY LOADING 300 PSF.
  - VAULT TO BE PLACED ON A MIN. 6" BASE OF CRUSHER RUN FOR EASE OF INSTALLATION AND EVEN LOAD DISTRIBUTION.
  - (4) 1/2" x 2 1/2" HEX HEAD BOLTS INSTALLED IN 1/2" INSERTS FOR GUARD BAR STORAGE AS SHOWN IN DRAWING.
- ORDERING INFORMATION:**
- K66-FH52-R4-15 FOR ASSEMBLY AS SHOWN.  
 APPROVED FOR SO. CALIF. GAS CO. I.D. # N399779  
 TOTAL WEIGHT OF ASSEMBLY SHOWN IS 11,926 Lbs.

- PB66-B16-R4-15, 16" BOTTOM SECTION, WT. 6,888 Lbs.
- PB66-TR31-R4-15, 31" TOP RING SECTION, WT. 5,038 Lbs.
- F66-PB-SA, 6' x 6' SPRING ASSISTED FRAME 5"x3", WT. 262 Lbs.
- SC66-PSREV-15 (2) PIECE SPRING ASSISTED PARKWAY COVER, GALV. SLIP RESISTANT, 12" x 13" DIA. SUMP x 5" DEEP W/SUMP RECESS, BOTTOM SECTION (1) CORE MTD. WITH COVER PLATE
- 6A. 6" DIA. HOLE, (2) CORE MTD. @ JOINT.
- 6B. 8" DIA. HOLE, (2) CORE MTD. @ JOINT.
- 2"DIA KNOCKOUT x 5" DEEP, TOP SECTION (4) CORE MTD.
- 6" x 7" DIA K.O. x 5" DEEP (5000-336), TOP & BOTTOM SECTION (1) EACH CORE MTD.
- 1 5/8" x 1 5/8" GALV. UNISTRUT x 6" LONG, TOP SECTION (4) CORE MTD.
- 1/2" P-35-T INSERT, BOTTOM SECTION (4) CORE MTD.; TOP SECTION (12) PALLET MTD.
- 1/2" PLASTIC INSERT, BOTTOM SECTION (2) CORE MTD. TOP SECTION (4) CORE MTD.
- GALV. LADDER x 36 1/2" LONG. W/TELESCOPIC LADDER GUIDES

**GENERAL NOTES:**

- Minimum soil bearing capacity is hereby assumed to be 2000 PSF unless otherwise documented by a geotechnical report that shall be provided to Jensen Precast by the end user. Jensen Precast shall not be held responsible for the soil bearing capacity.
- Installation of Manholes, Vaults, Handholes, Meter Boxes, etc. will be as per Jensen installation procedures.
- Structural modification to the Jensen line of products is not permitted without prior written approval from Jensen Engineering Department.
- Do not scale the drawings, verify all dimensions including rough openings, if any discrepancies are found, notify the Jensen Engineer immediately.
- The Jensen Engineer will interpret the intent of the drawings in case of possible conflict or discrepancy.
- Permissible Variations:**  
 Dimensional Tolerances – The length, width, height, or dia. measurements of the structure when measured on the inside surfaces shall not deviate from design dimensions by more than the following:  
 Dimensions: Tolerance:  
 0 to 5 Feet 1/4"  
 5 to 10 Feet 3/8"  
 10 to 20 Feet as agreed upon between the supplier and purchaser.  
 Squariness Tolerance:  
 The inside of the precast concrete component shall be square as determined by diagonal measurements. The difference between such measurements shall not exceed the following:  
 Measured Length: Allowable Difference  
 0 to 10 Feet 1/2"  
 10 to 20 Feet 3/4"  
 20 Feet and over as agreed upon between the supplier and purchaser.

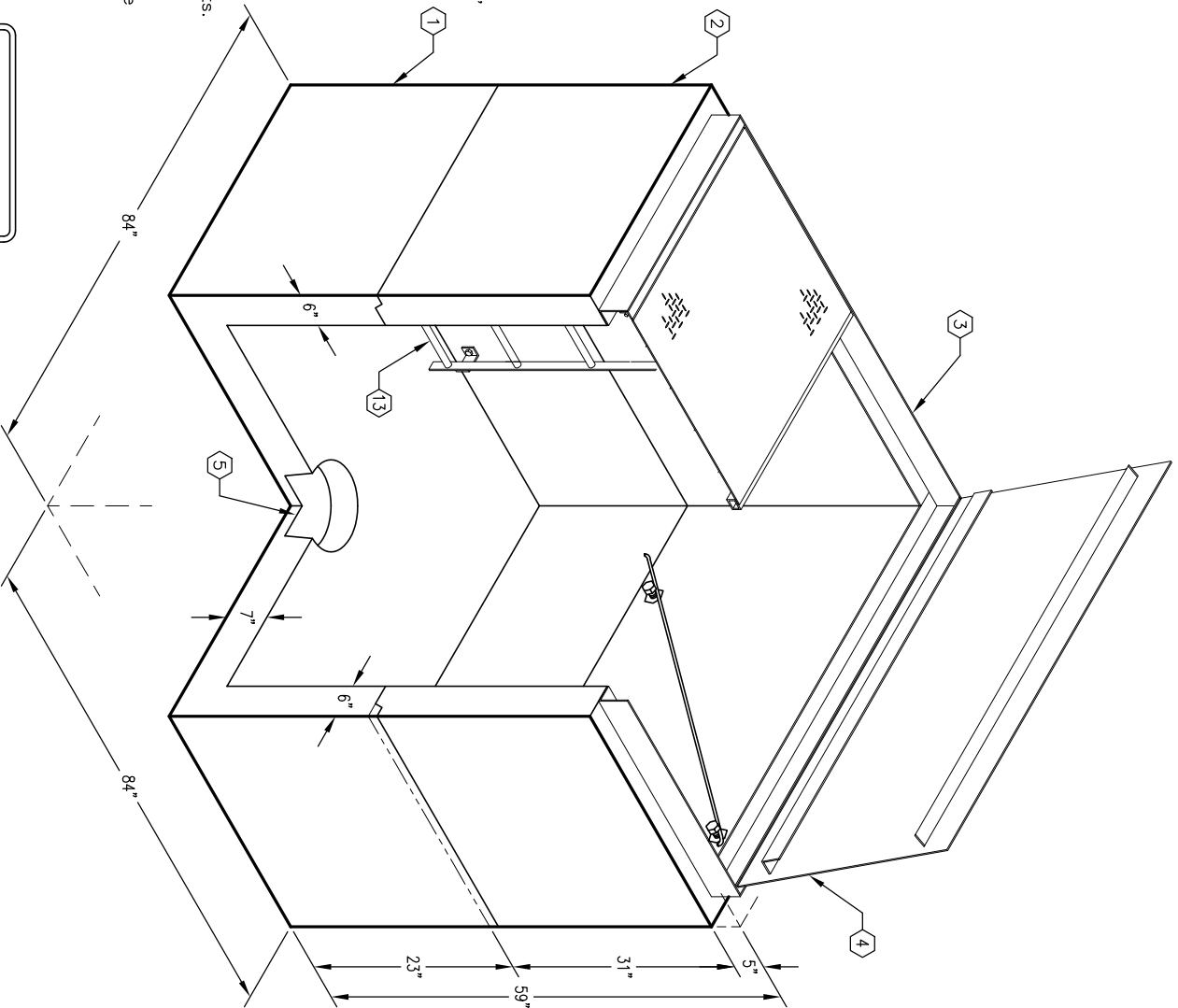

AUTOCAD REL. 14

MINIMUM EXCAVATION SIZE:  
 8'-0" x 8'-0" x DEPTH REQ'D.

K66-FH52-R4-15

PER SO. CAL. GAS CO. SPEC. N399779

03-01-02

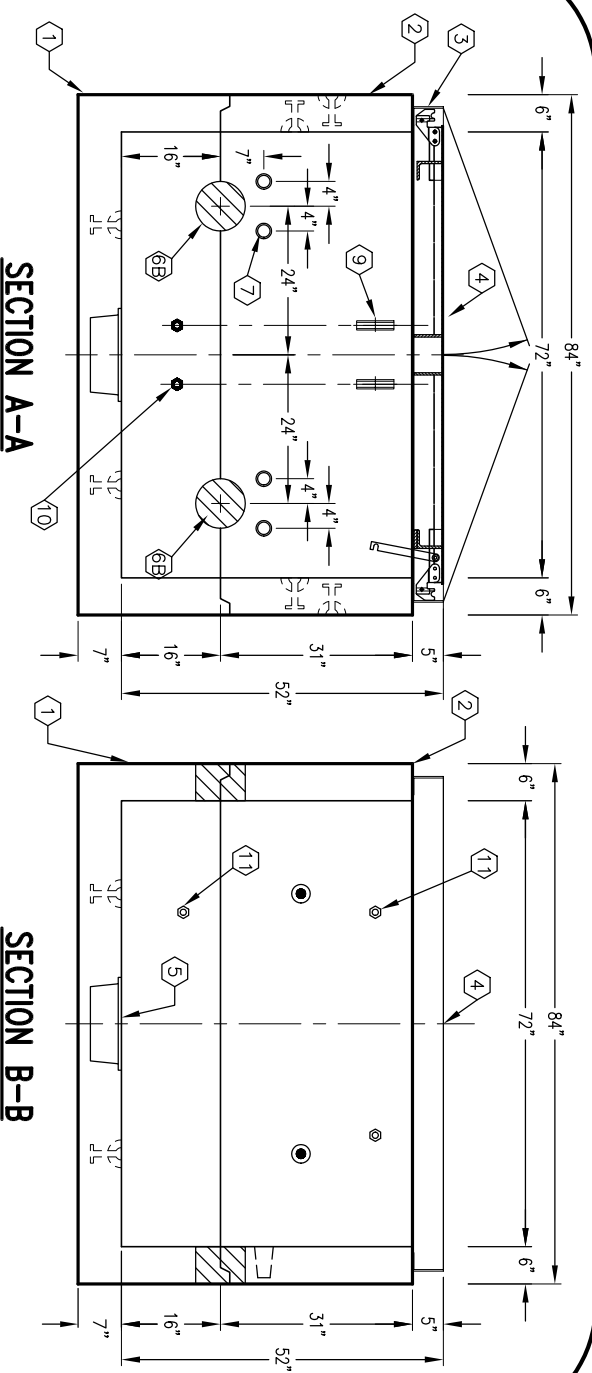

SECTION A-A

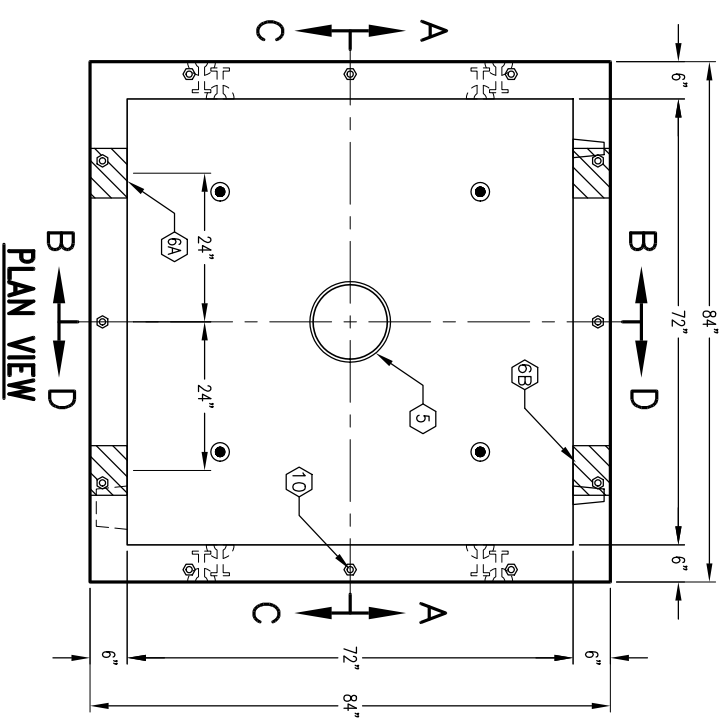

PLAN VIEW

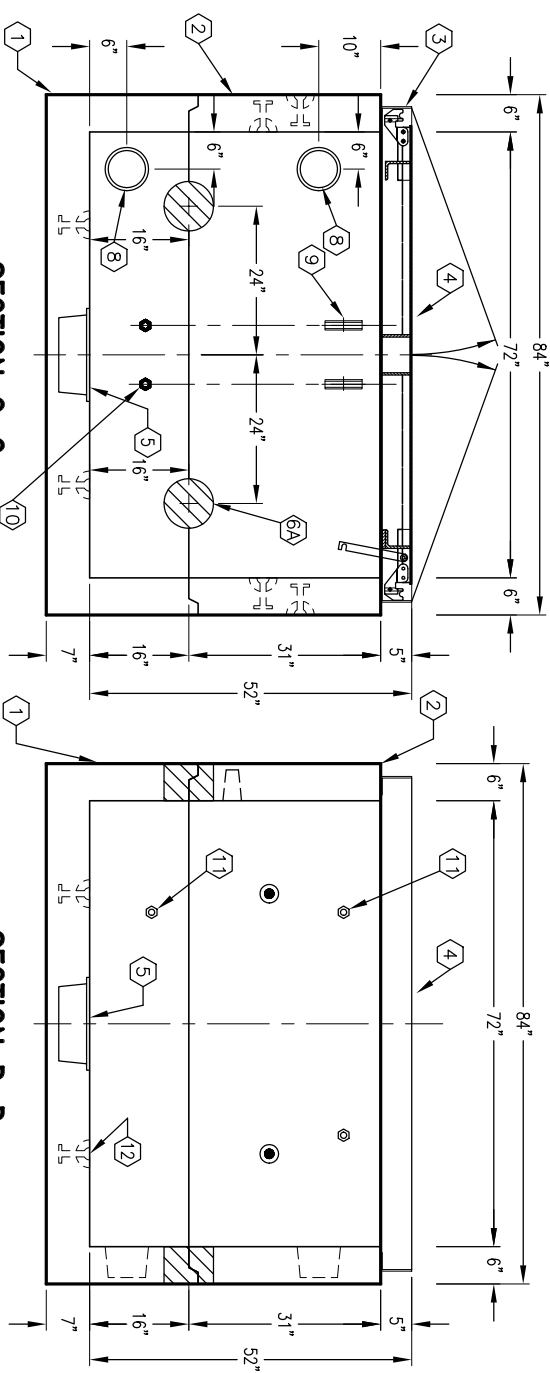

SECTION C-C

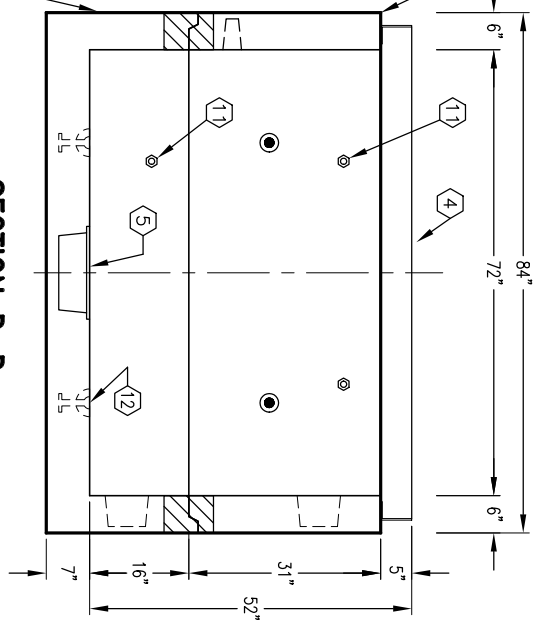

SECTION D-D



K66-FH52-R4-15

PER SO. CAL. GAS CO. SPEC. N399779

03-01-02

#	DATE	DESCRIPTION	BY