

6'-0" x 6'-0" SCG PARKWAY FLOORLESS VAULT (N399772) x 59" DEEP-2" & 3" REGULATOR

- NOTES:**
- HANDHOLE DESIGNED IN ACCORDANCE WITH ASHTO H-20-44 TRAFFIC BRIDGE LOADING USING 5,500 PSI [37.92MPa] COMPRESSIVE STRENGTH CONCRETE AND 60,000 PSI [413.2MPa] YIELD STRENGTH ASTM A-706 STEEL REINFORCEMENT PER CALCS. #
 - COVER DESIGNED FOR PARKWAY LOADING 300 PSF.
 - VAULT TO BE PLACED ON A MIN. 6" BASE OF CRUSHER RUN FOR EASE OF INSTALLATION AND EVEN LOAD DISTRIBUTION.
 - (4) 1/2" x 2 1/2" HEX HEAD BOLTS INSTALLED IN 1/2" INSERTS FOR GUARD BAR STORAGE AS SHOWN IN DRAWING.
- ORDERING INFORMATION:**
- K66-FH59-15 FOR ASSEMBLY AS SHOWN.
 APPROVED FOR SO. CALIF. GAS CO. I.D. # N399772
 TOTAL WEIGHT OF ASSEMBLY SHOWN IS 9,120 Lbs.

- PB66-L23-15, 23" LOWER SECTION, WT. 3,800 Lbs.
- PB66-TR31-15, 31" TOP RING SECTION, WT. 5,038 Lbs.
- F66-PB-SA, 6" x 6" SPRING ASSISTED FRAME 5"x3" WT. 262 Lbs.
- SC66-PSRCV-15 (2) PIECE SPRING ASSISTED PARKWAY COVER, GALV. SLIP RESISTANT.
- 4" DIA HOLE, (4) CORE MTD. @ JOINT.
- 2" DIA HOLE, TOP SECTION (4) CORE MTD.
- 6" x 7" DIA K.O. x 5" DEEP (5000-336). TOP & BOTTOM SECTION (1) EACH CORE MTD.
- 1 5/8" x 1 5/8" GALV. UNISTRUT x 6" LONG, TOP SECTION (2) CORE MTD.
- 1/2" P-35-T INSERT, TOP SECTION (12) PALLET MTD.
- LOWER SECTION (2) CORE MTD.
- 1/2" PLASTIC INSERT, LOWER SECTION (4) CORE MTD.
- GALV. LADDER x 48 1/2" LONG. W/TELESCOPIC LADDER GUIDES (SL-15-48).

GENERAL NOTES:

- Minimum soil bearing capacity is hereby assumed to be 2000 PSF unless otherwise documented by a geotechnical report that shall be provided to Jensen Precast by the end user. Jensen Precast shall not be held responsible for the soil bearing capacity.
- Installation of Manholes, Vaults, Handholes, Meter Boxes, etc. will be as per Jensen installation procedures.
- Structural modification to the Jensen line of products is not permitted without prior written approval from Jensen Engineering Department.
- Do not scale the drawings, verify all dimensions including rough openings, if any discrepancies are found, notify the Jensen Engineer immediately.
- The Jensen Engineer will interpret the intent of the drawings in case of possible conflict or discrepancy.
- Permissible Variations:**
 Dimensional Tolerances – The length, width, height, or dia. measurements of the structure when measured on the inside surfaces shall not deviate from design dimensions by more than the following:
 Dimensions: Tolerance:
 0 to 5 Feet 1/4"
 5 to 10 Feet 3/8"
 10 to 20 Feet as agreed upon between the supplier and purchaser.
 Squareness Tolerance:
 The inside of the precast concrete component shall be square as determined by diagonal measurements. The difference between such measurements shall not exceed the following:
 Measured Length: Allowable Difference
 0 to 10 Feet 1/2"
 10 to 20 Feet 3/4"
 20 Feet and over as agreed upon between the supplier and purchaser.

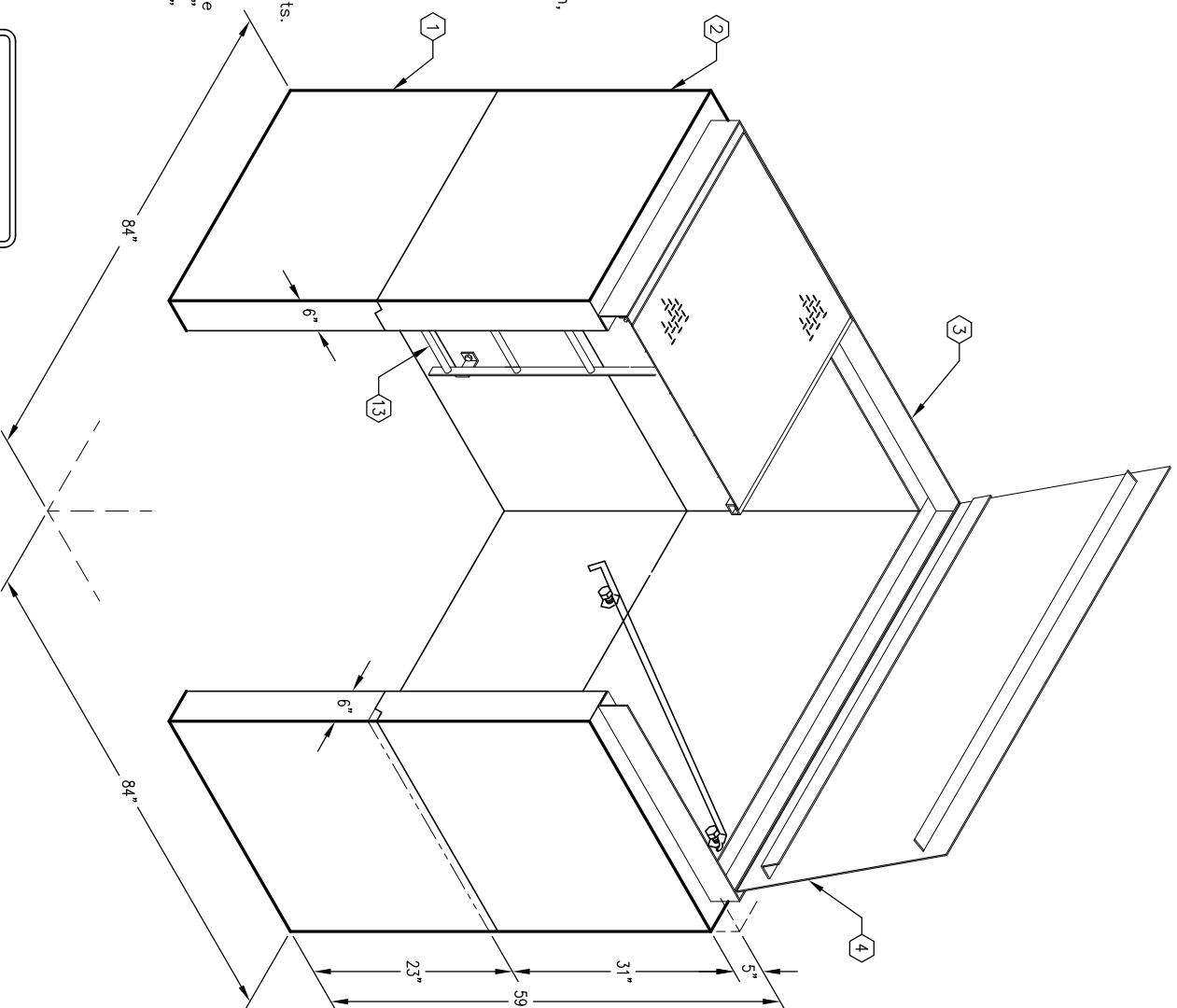

AUTOCAD REL. 14

MINIMUM EXCAVATION SIZE:
 8'-0" x 8'-0" x DEPTH REQD.

K66-FH59-15

PER SO. CAL. GAS CO. SPEC. N399772

03-01-02

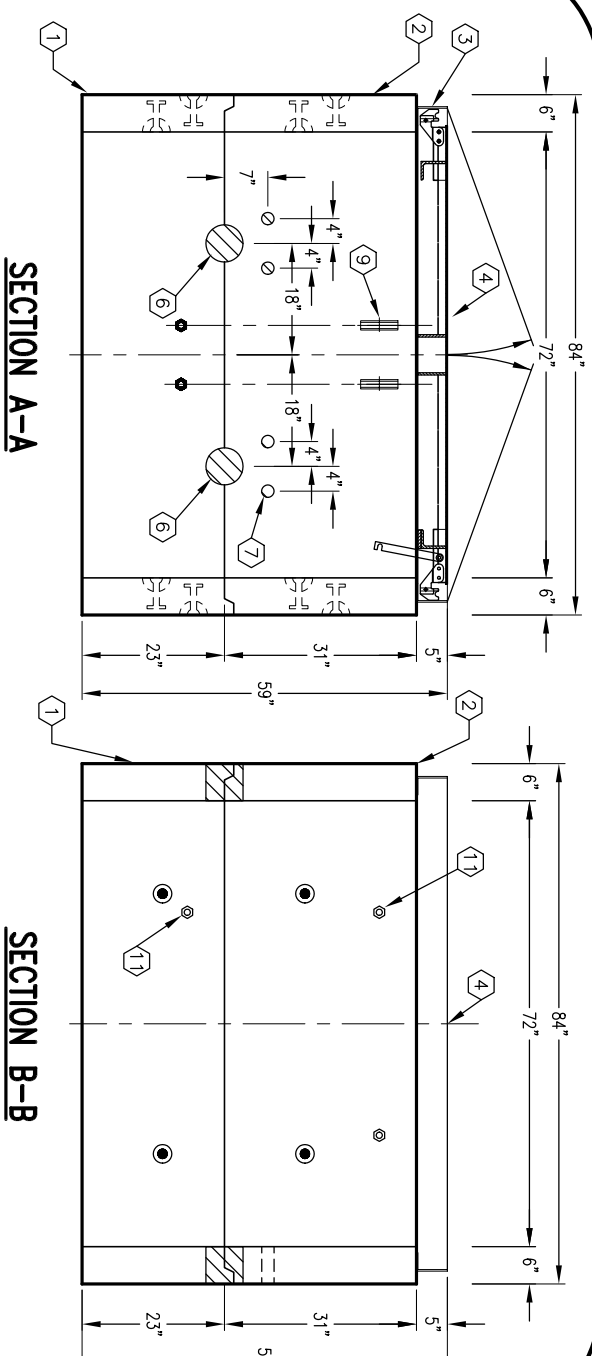

SECTION A-A

SECTION B-B

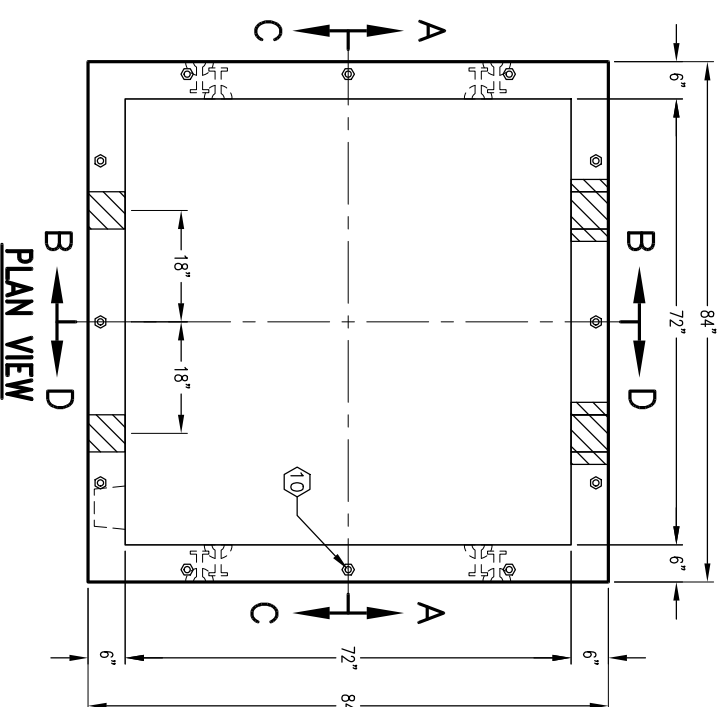

PLAN VIEW

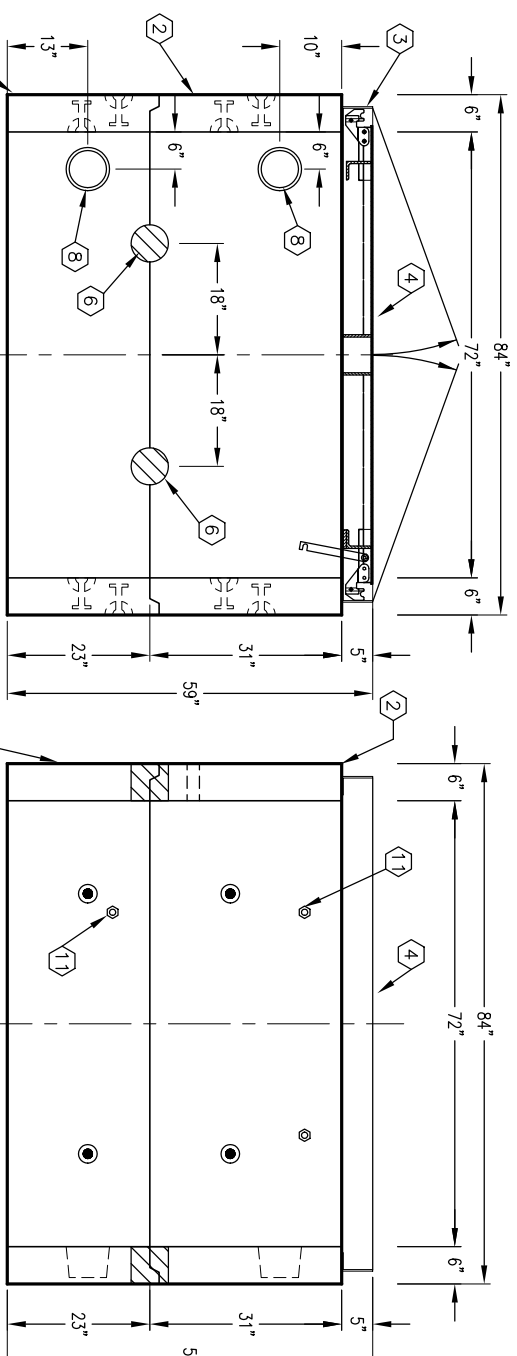

SECTION C-C

SECTION D-D



K66-FH59-15

PER SO. CAL. GAS CO. SPEC. N399772

03-01-02

#	DATE	DESCRIPTION	BY