

6'-0" x 6'-0" SCG PARKWAY HANDHOLE (76-9408) x 5'-0" DEEP

NOTES:

- HANDHOLE DESIGNED IN ACCORDANCE WITH AASHTO H-20-44 TRAFFIC BRIDGE LOADING USING 5,500 PSI [37.92MPa] COMPRESSIVE STRENGTH CONCRETE AND 60,000 PSI [413.2MPa] YIELD STRENGTH ASTM A-706 STEEL REINFORCEMENT PER CALCS. #31171.
 - COVER DESIGNED FOR PARKWAY LOADING PER CALC. #31178.
 - SEE CALC. #31174 AND DRAWING NUMBER 660-184 FOR TRAFFIC APPLICATIONS.
 - HANDHOLE BOX TO BE PLACED ON A MIN. 6" BASE OF CRUSHER RUN FOR EASE OF INSTALLATION AND EVEN LOAD DISTRIBUTION.
 - (4) 1/2" x 2 1/2" HEX HEAD BOLTS INSTALLED IN 1/2" INSERTS FOR GUARD BAR STORAGE AS SHOWN IN DRAWING.
- ORDERING INFORMATION:**
- K66-FH60-15PF FOR ASSEMBLY AS SHOWN.
 APPROVED FOR SO. CALIF. GAS CO. I.D. #76-9408
 TOTAL WEIGHT OF ASSEMBLY SHOWN IS 14,266 Lbs.

1. PB66-B42-15, 42" BOTTOM SECTION, WT. 11,005 Lbs.
2. PB66-T14-15, 14" TOP SECTION, WT. 2,254 Lbs.
3. 5" SPRING ASSISTED ADJUSTABLE FRAME (F66-PB-GAS), WT. 303 Lbs.
4. CA66-PGRSA (2) PIECE SPRING ASSISTED PARKWAY COVER SC66-PSRGV-15 W/(2) CAMLOCKS, (2) LIFT HANDLES, (1) 1/2" ALLEN HEAD BUTTON CAP SCREW, (2) GUARD BARS (NOT GALV.), GALV. ASSY. WT. 704 Lbs.
5. 12" x 13" DIA. SUMP x 5" DEEP W/ SUMP RECESS.
6. 8" x 9" DIA. K.O. x 5" DEEP, BOTTOM SECTION
7. 6" x 7" DIA. K.O. x 5" DEEP, BOTTOM SECTION
8. 2" x 3" DIA. K.O. x 5" DEEP, BOTTOM SECTION
9. 1 5/8" x 1 5/8" GALV. UNISTRUT x 6" LONG, TOP SECTION
10. (2) CORE MTD.
11. (4) CORE MTD.
12. (2) CORE MTD.
13. GALV. LADDER x 54 1/2" LONG. W/ TELESCOPIC LADDER GUIDES (SL-15-48).

GENERAL NOTES:

1. Minimum soil bearing capacity is hereby assumed to be 2000 PSF unless otherwise documented by a geotechnical report that shall be provided to Jensen Precast by the end user. Jensen Precast shall not be held responsible for the soil bearing capacity.
2. Installation of Manholes, Vaults, Handholes, Meter Boxes etc. will be as per Jensen installation procedures.
3. Structural modification to the Jensen line of products is not permitted without prior written approval from Jensen Engineering Department.
4. Do not scale the drawings, verify all dimensions including rough openings, if any discrepancies are found, notify the Jensen Engineer immediately.
5. The Jensen Engineer will interpret the intent of the drawings in case of possible conflict or discrepancy.
6. Permissible Variations: Dimensional Tolerances – The length, width, height, or dia. measurements of the structure when measured on the inside surfaces shall not deviate from design dimensions by more than the following:
 Dimensions: Tolerance:
 0 to 5 Feet 1/4"
 5 to 10 Feet 3/8"
 10 to 20 Feet as agreed upon between the supplier and purchaser.
 Squariness Tolerance: The inside of the precast concrete component shall be square as determined by diagonal measurements. The difference between such measurements shall not exceed the following:
 Measured Length: Allowable Difference
 0 to 10 Feet 1/2"
 10 to 20 Feet 3/4"
 20 Feet and over as agreed upon between the supplier and purchaser.
- 7.

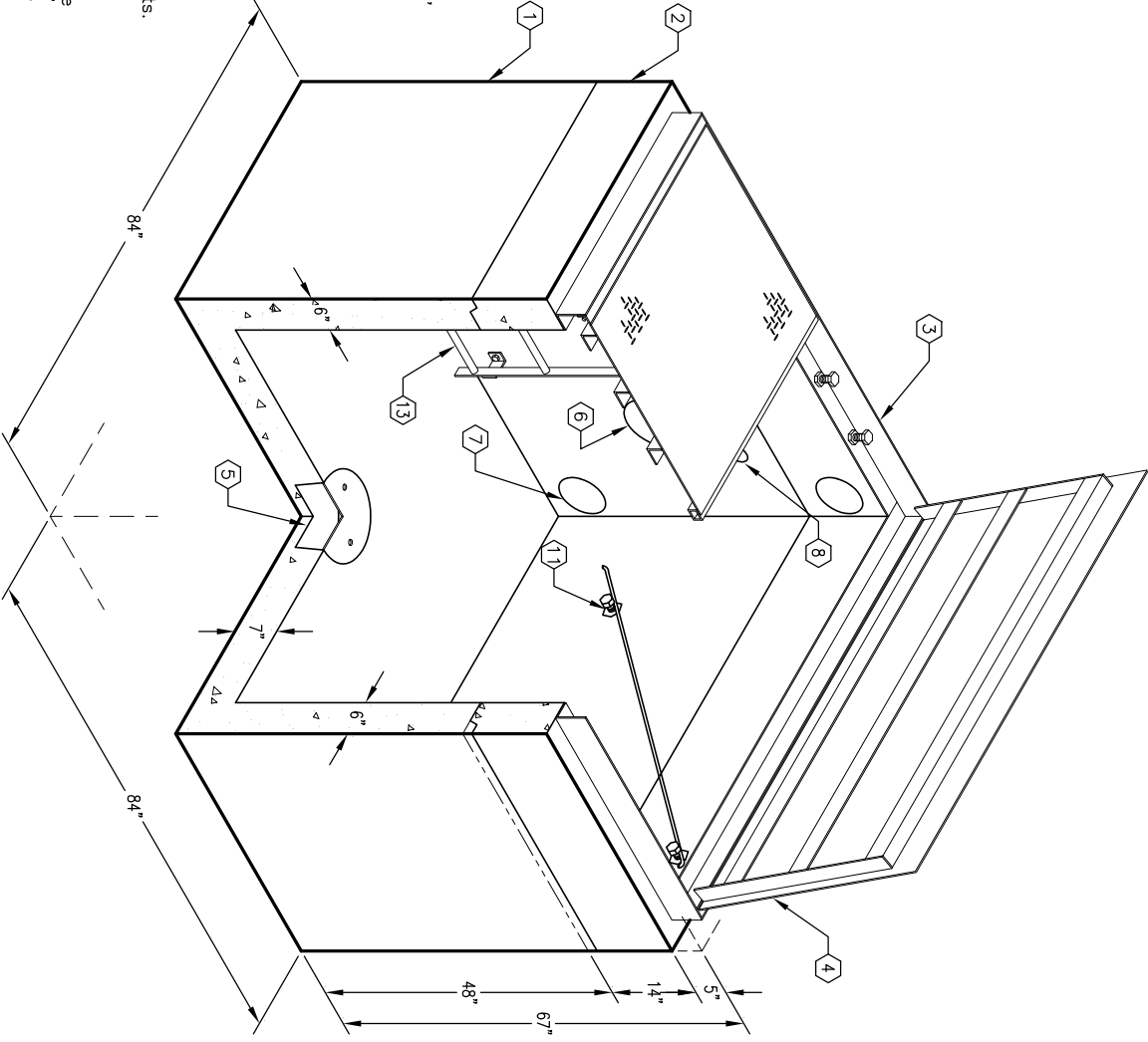

MINIMUM EXCAVATION SIZE:
 8'-0" x 8'-0" x DEPTH REQ'D.

K66-FH60-15PF

PER SO. CAL. GAS CO. SPEC. 76-9408 03-01-02

JENSEN PRECAST

#	DATE	DESCRIPTION	BY

K66-FH60-15PF

PER SO. CAL. GAS CO. SPEC. 76-9408 03-01-02

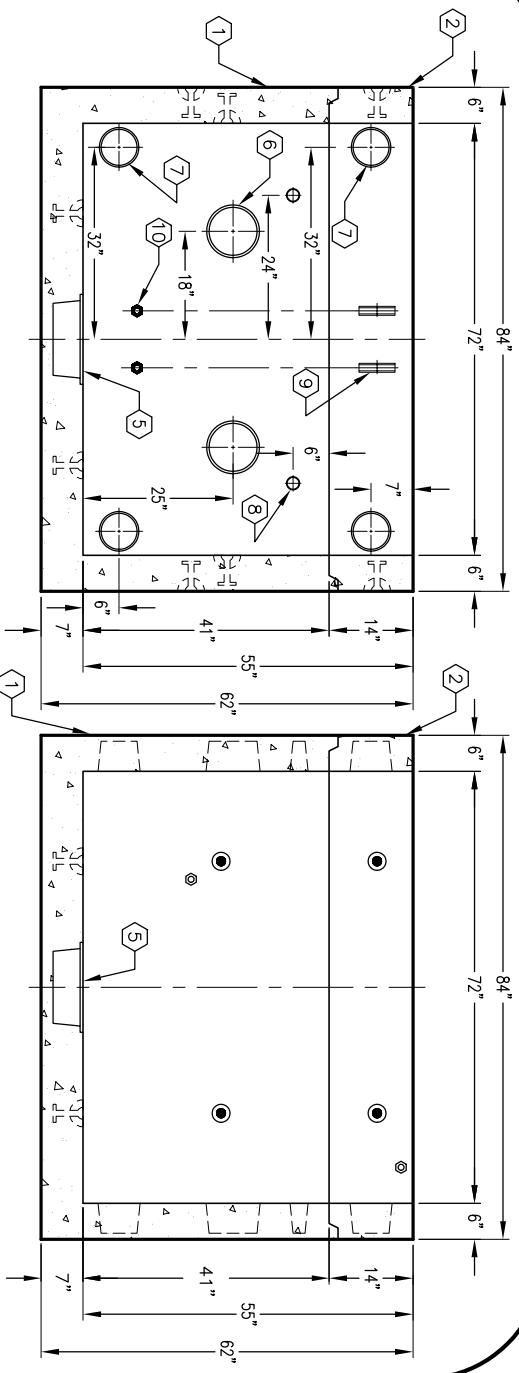

SECTION A-A

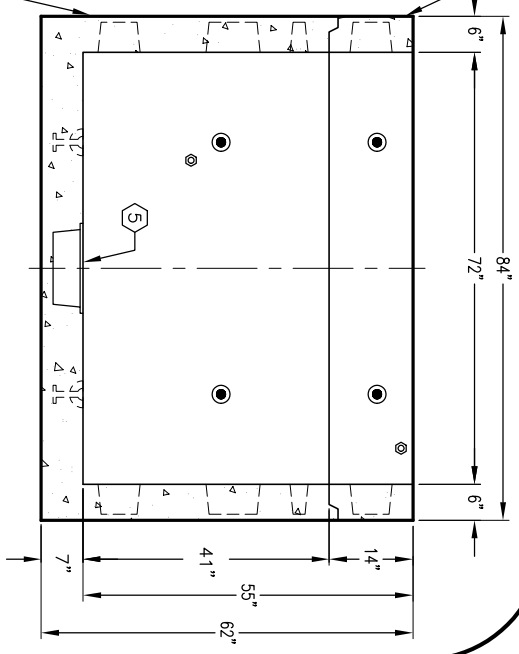

SECTION B-B

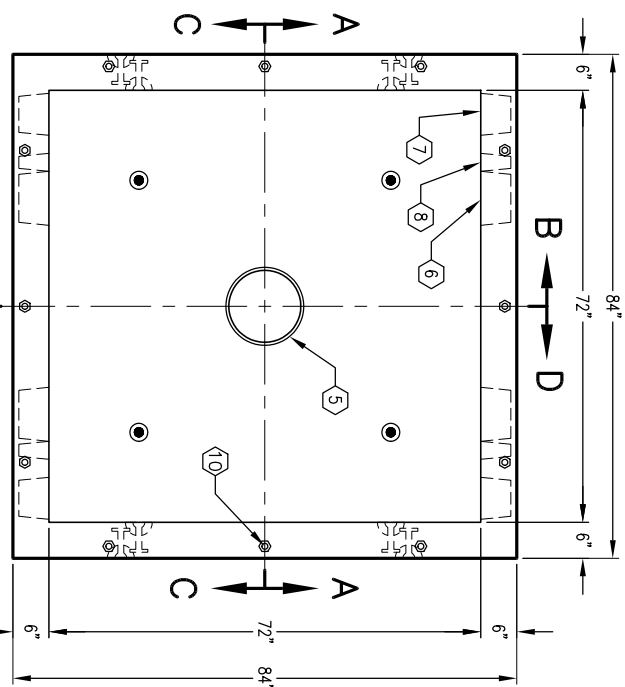

PLAN VIEW

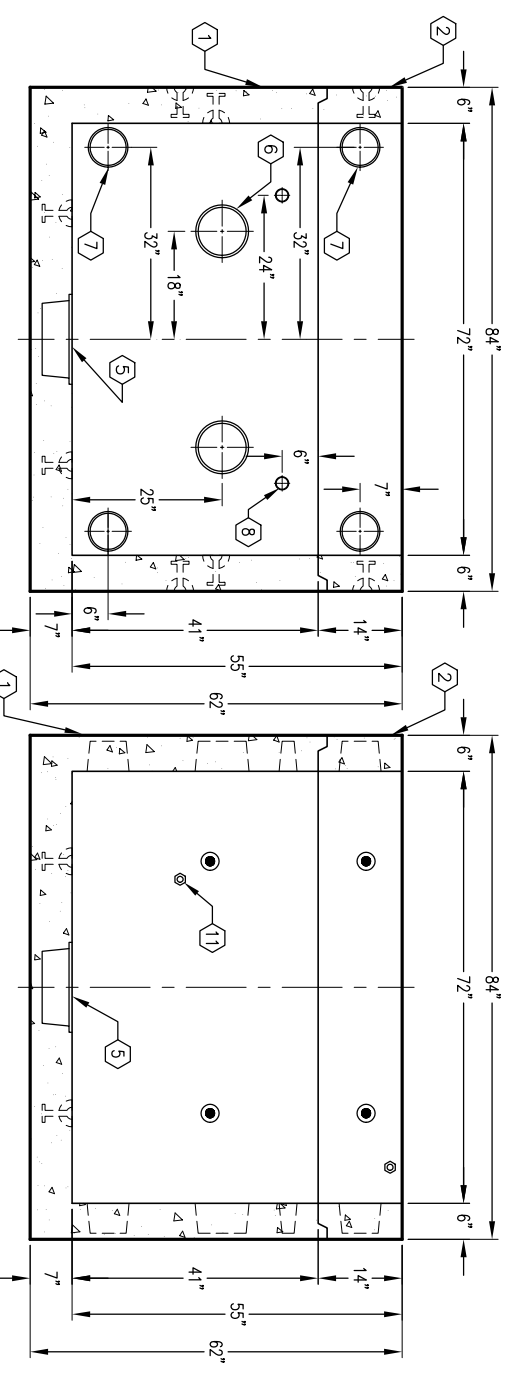

SECTION C-C

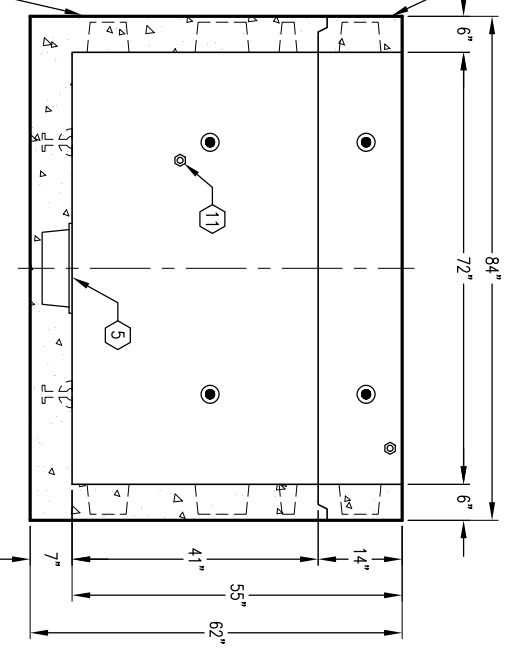

SECTION D-D