

4'-0" X 4'-0" SCG PARKWAY HANDHOLE X 5'-0" DEEP

NOTES:

- DESIGNED IN ACCORDANCE WITH AASHTO H-20-44 BRIDGE LOADING USING 5,500 PSF [37.92MPa] COMPRESSIVE STRENGTH CONCRETE AND 60,000 PSI [413.2MPa] YIELD STRENGTH GRADE 60 A-706 STEEL REINFORCEMENT PER CALC. #31167.
- COVER DESIGNED PER CALC. #31176.
- SEE CALC. #31172 AND DRAWING NUMBER 300-162 FOR TRAFFIC APPLICATIONS.
- VAULT TO BE PLACED ON A MIN. 6" BASE OF CRUSHER RUN FOR EASE OF INSTALLATION AND EVEN LOAD DISTRIBUTION.

ORDERING INFORMATION:

K44X-FHL60-15PSR FOR ASSEMBLY AS SHOWN, APPROVED FOR SO. CAL. GAS CO. SPEC. 76-9402 TOTAL WEIGHT OF ASSEMBLY IS 7,884 Lbs.

- 1. PB44X-155-15, 55" LOWER SECTION, WT. 7,388 Lbs.
- 2. 5" GALVANIZED ADJUSTABLE FRAME, F44-PB-GAS-A, WT. 176 Lbs.
- 3. C44X-PGSRSA-15, 2 PIECE GALVANIZED SPRING ASSISTED PARKWAY SLIP RESISTANT COVER ASSEMBLY (SC44-PSRGV-15) W/ GUARD BARS, SPECIAL CAMLOCKS, (2) LIFT HANDLES AND (1) 1/2" ALLEN BUTTON HEAD CAP SCREW, WT. 320 Lbs.
- 4. 8" x 9" DIA. x 5" DEEP (5000-335). LOCATE AS FOLLOWS:
LOWER SECTION (4) CORE MTD.
- 5. 2" x 3" DIA. x 5" DEEP. LOCATE AS FOLLOWS: LOWER SECTION (2) CORE MTD.
- 6. LADDER (SL-15-48) MOUNTED ON EITHER SIDE. (NOT SHOWN)
- 7. 1/2-35-T INSERT. LOCATE AS FOLLOWS:
LOWER SECTION (16) CORE MTD.

GENERAL NOTES:

1. Minimum soil bearing capacity is hereby assumed to be 2000 PSF unless otherwise documented by a geotechnical report that shall be provided to Jensen Precast by the end user. Jensen Precast shall not be held responsible for the soil bearing capacity.
2. Installation of Manholes, Vaults, Handholes, Meter Boxes etc. will be as per Jensen installation procedures.
3. Structural modification to the Jensen line of products is not permitted without prior written approval from Jensen Engineering Department.
4. Do not scale the drawings, verify all dimensions including rough openings, if any discrepancies are found, notify the Jensen Engineer immediately.
5. The Jensen Engineer will interpret the intent of the drawings in case of possible conflict or discrepancy.
6. Permissible Variations:
Dimensional Tolerances – The length, width, height, or dia. measurements of the structure when measured on the inside surfaces shall not deviate from design dimensions by more than the following:
Tolerance:
0 to 5 Feet 1/4"
5 to 10 Feet 3/8"
10 to 20 Feet as agreed upon between the supplier and purchaser.
Squarness Tolerance:
The inside of the precast concrete component shall be square as determined by diagonal measurements. The difference between such measurements shall not exceed the following:
Measured Length: Allowable Difference
0 to 10 Feet 1/2"
10 to 20 Feet 3/4"
20 Feet and over as agreed upon between the supplier and purchaser.
- 7.

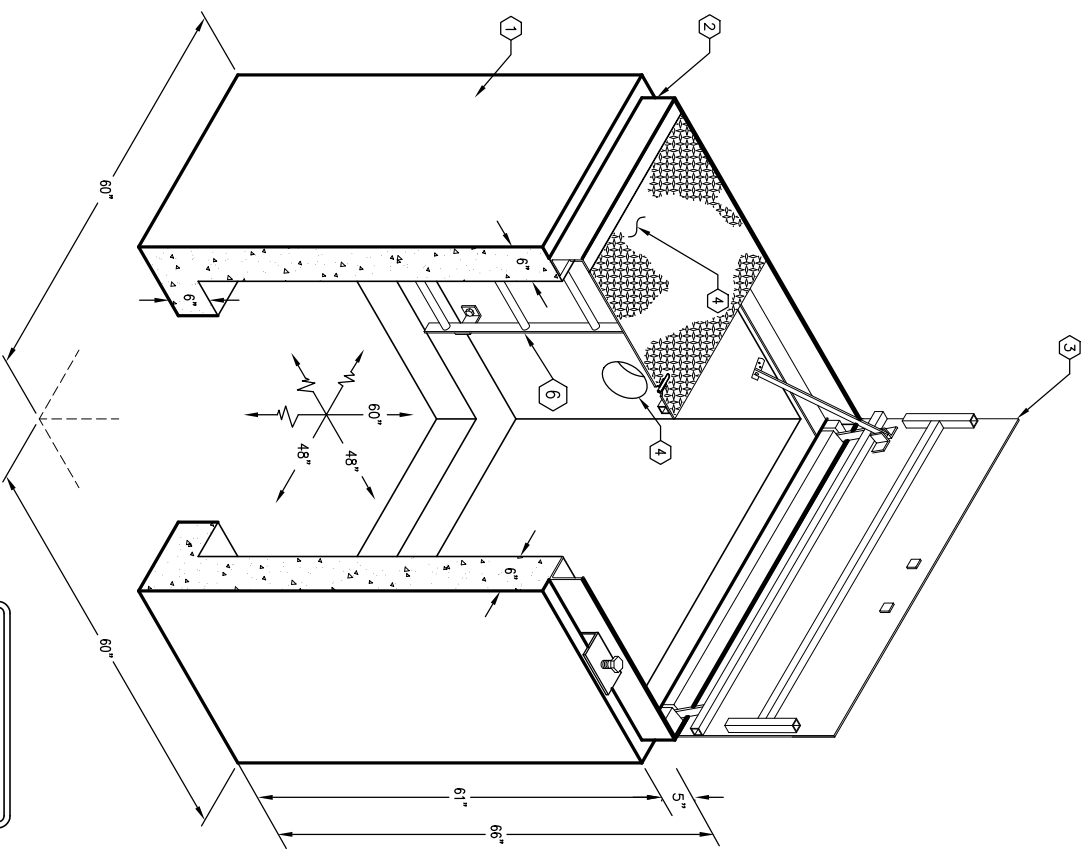

MINIMUM EXCAVATION SIZE:
6'-0" x 6'-0" x DEPTH REQ'D.

K44X-FHL60-15PSR

AUTODRAW REL. 14

JENSEN PRECAST

#	DATE	DESCRIPTION	BY

K44X-FHL60-15PSR

PER SO. CAL. GAS CO. 76-9402 MODIFIED

03-01-02

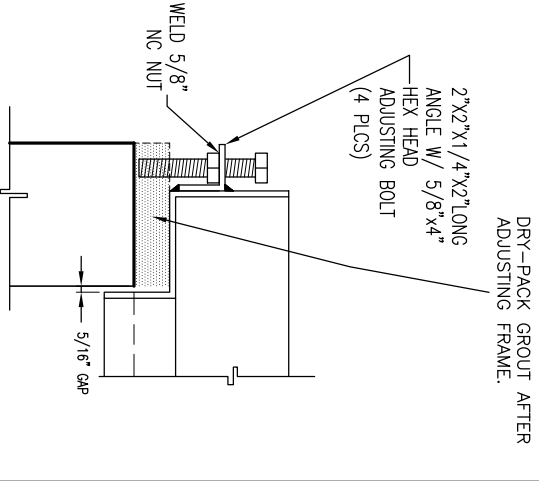
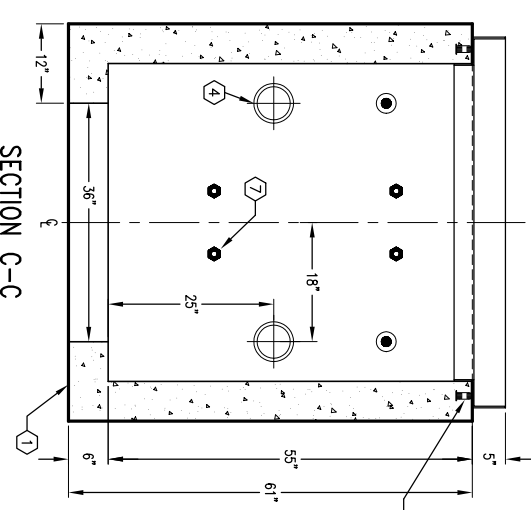
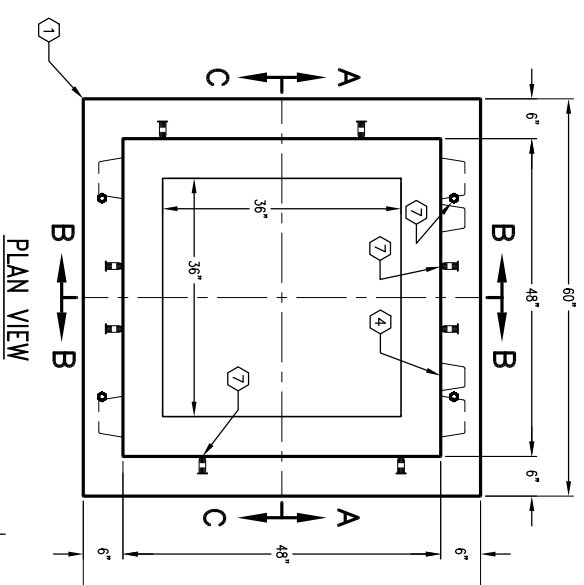
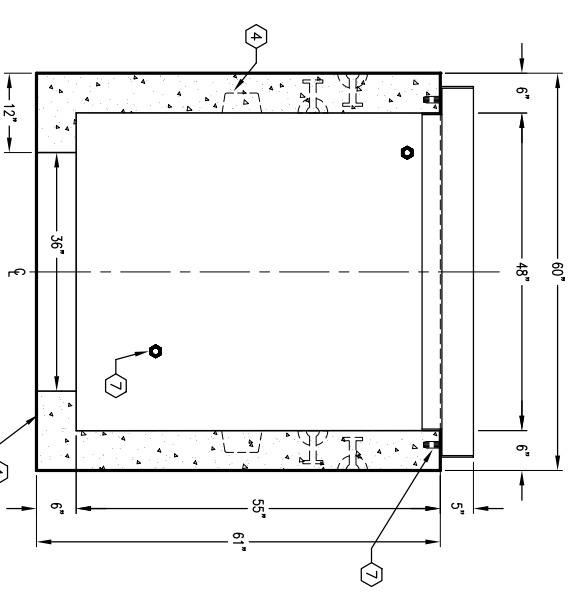
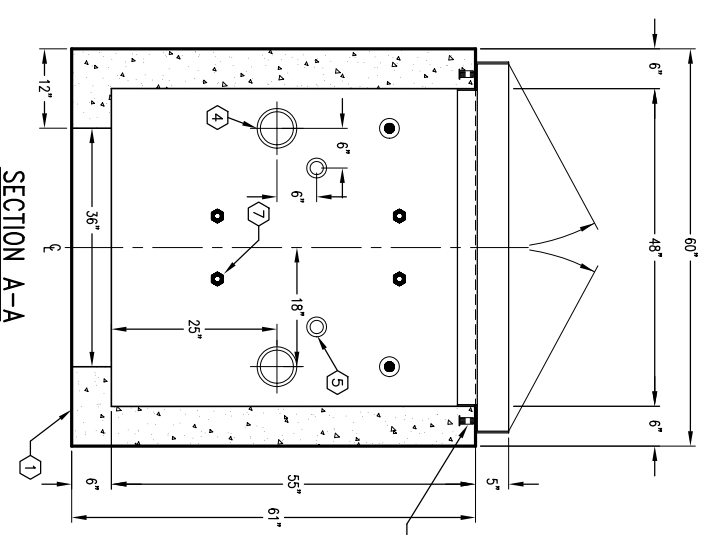

FRAME ADJUSTMENT IF REQ'D